

DCT-4 common baseband

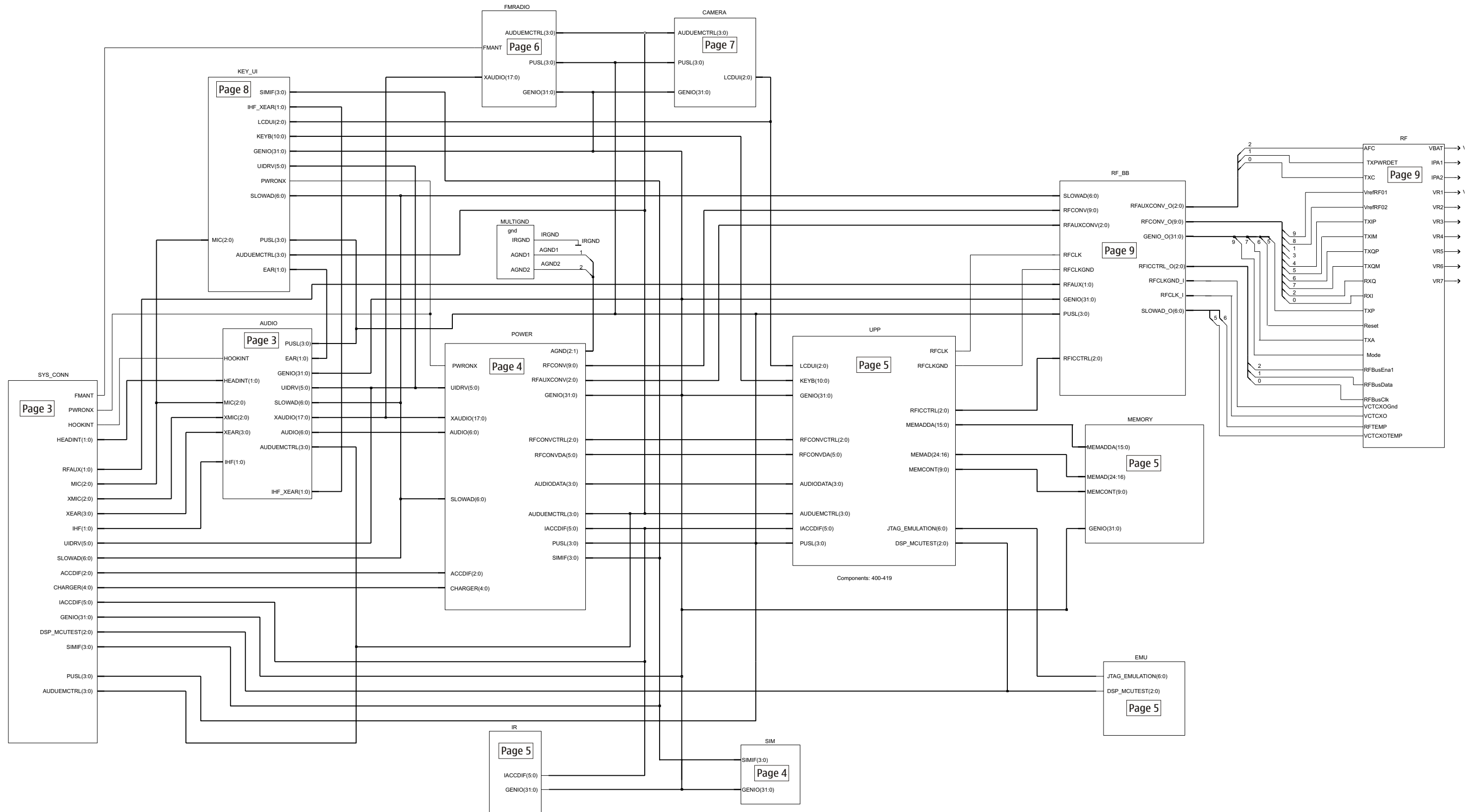

System connector, Audio

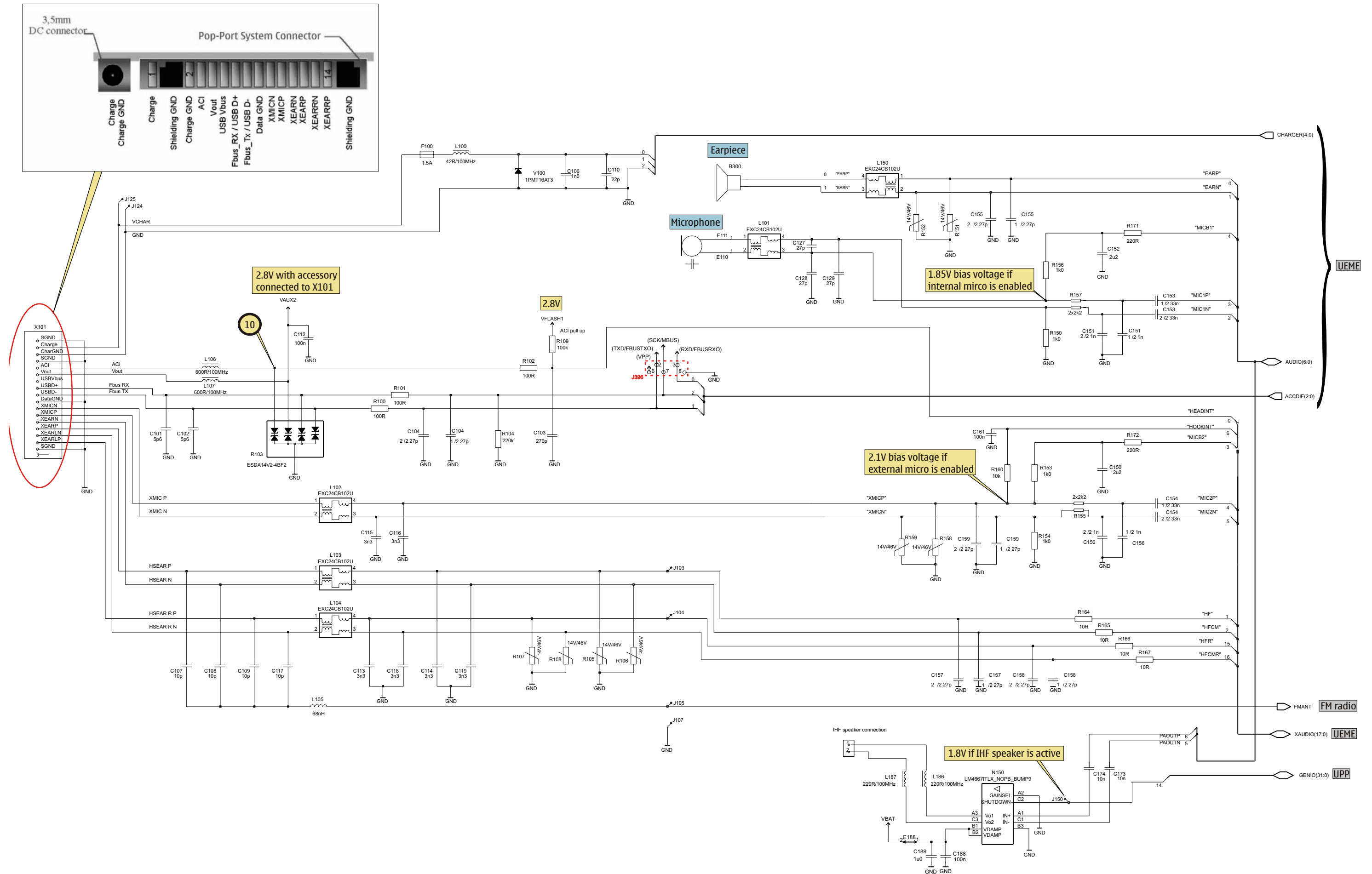

UEME, SIM

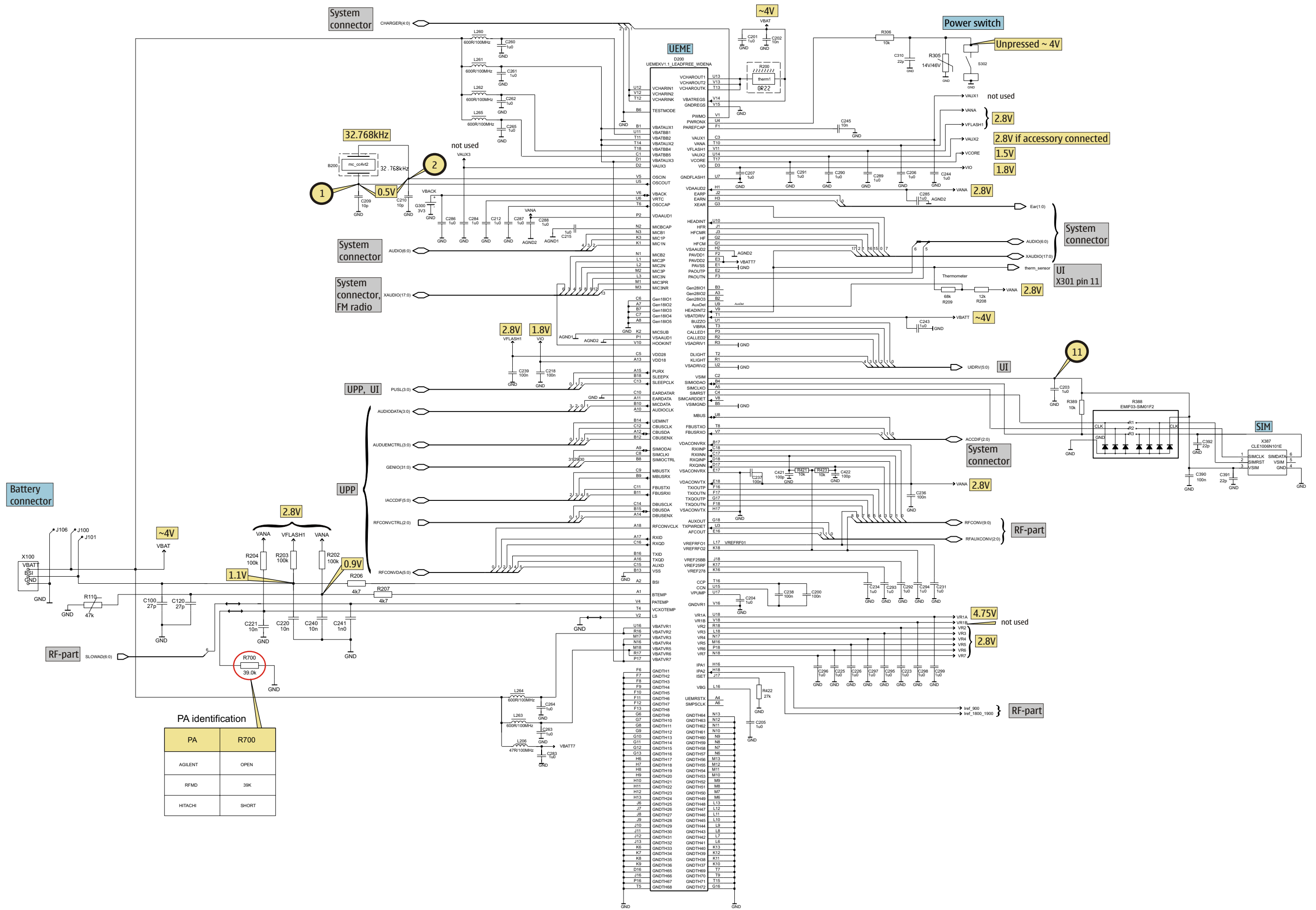

UPP, combo memory, IRDA

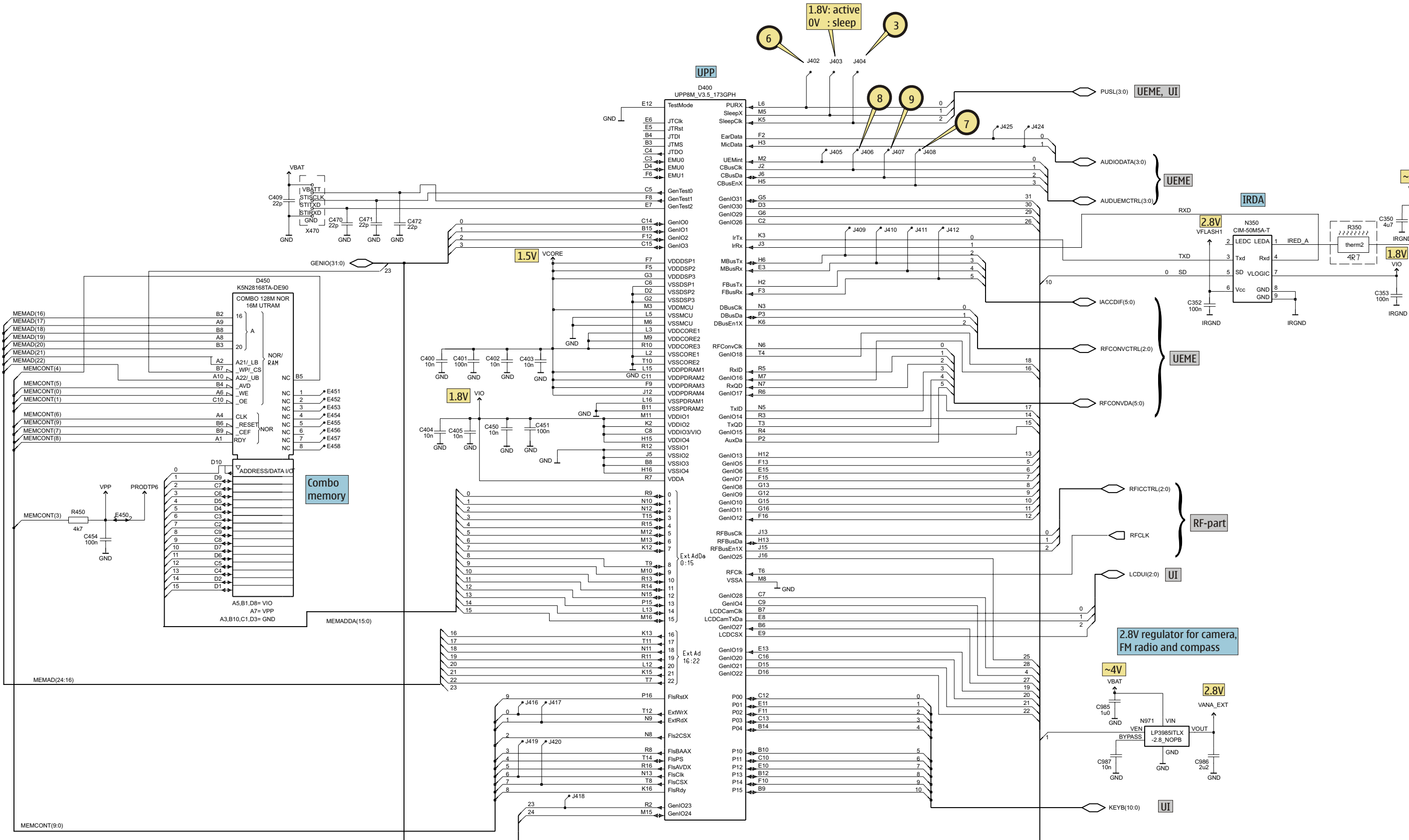

Camera, FM radio

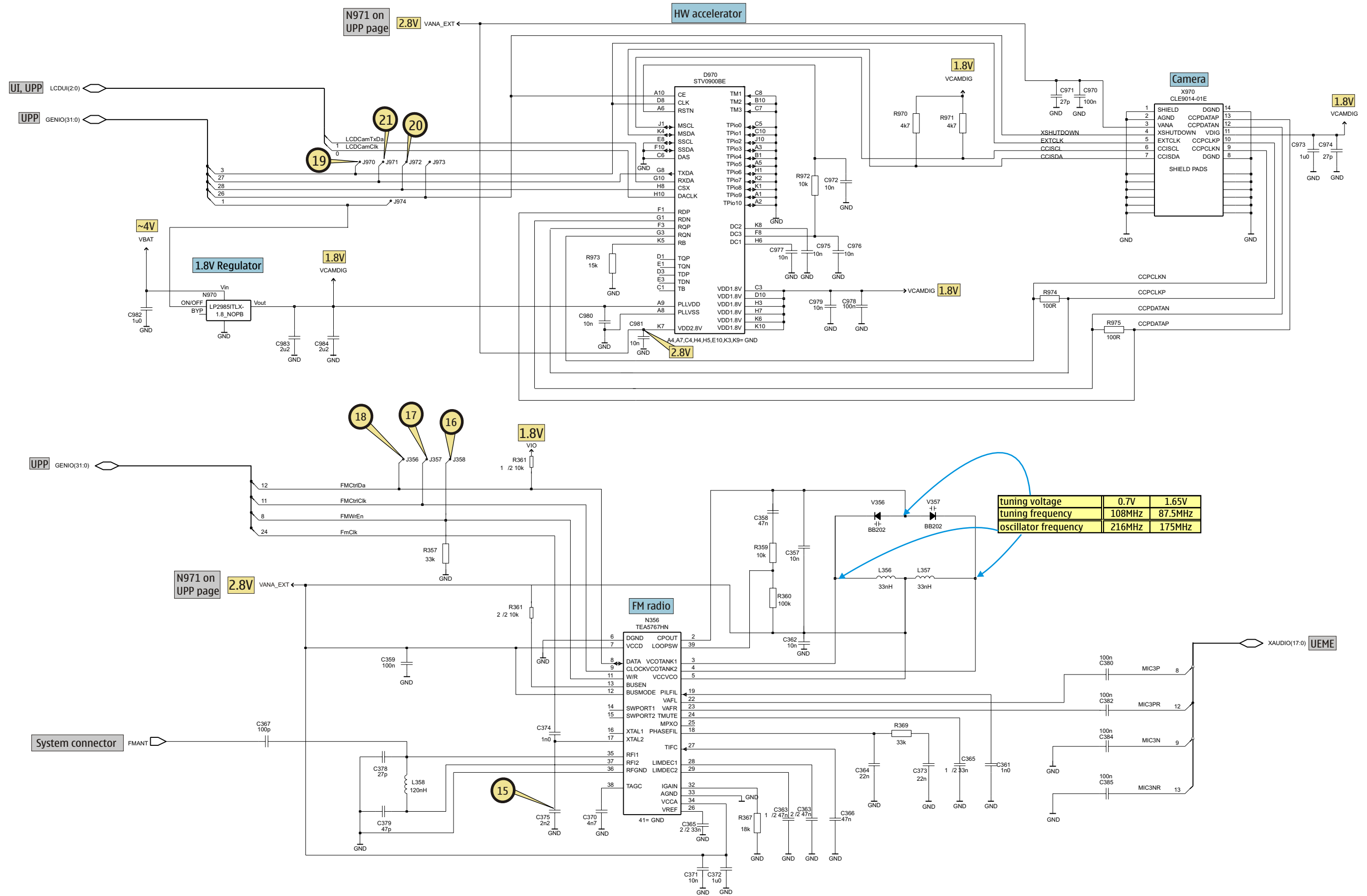

UI, Vibra

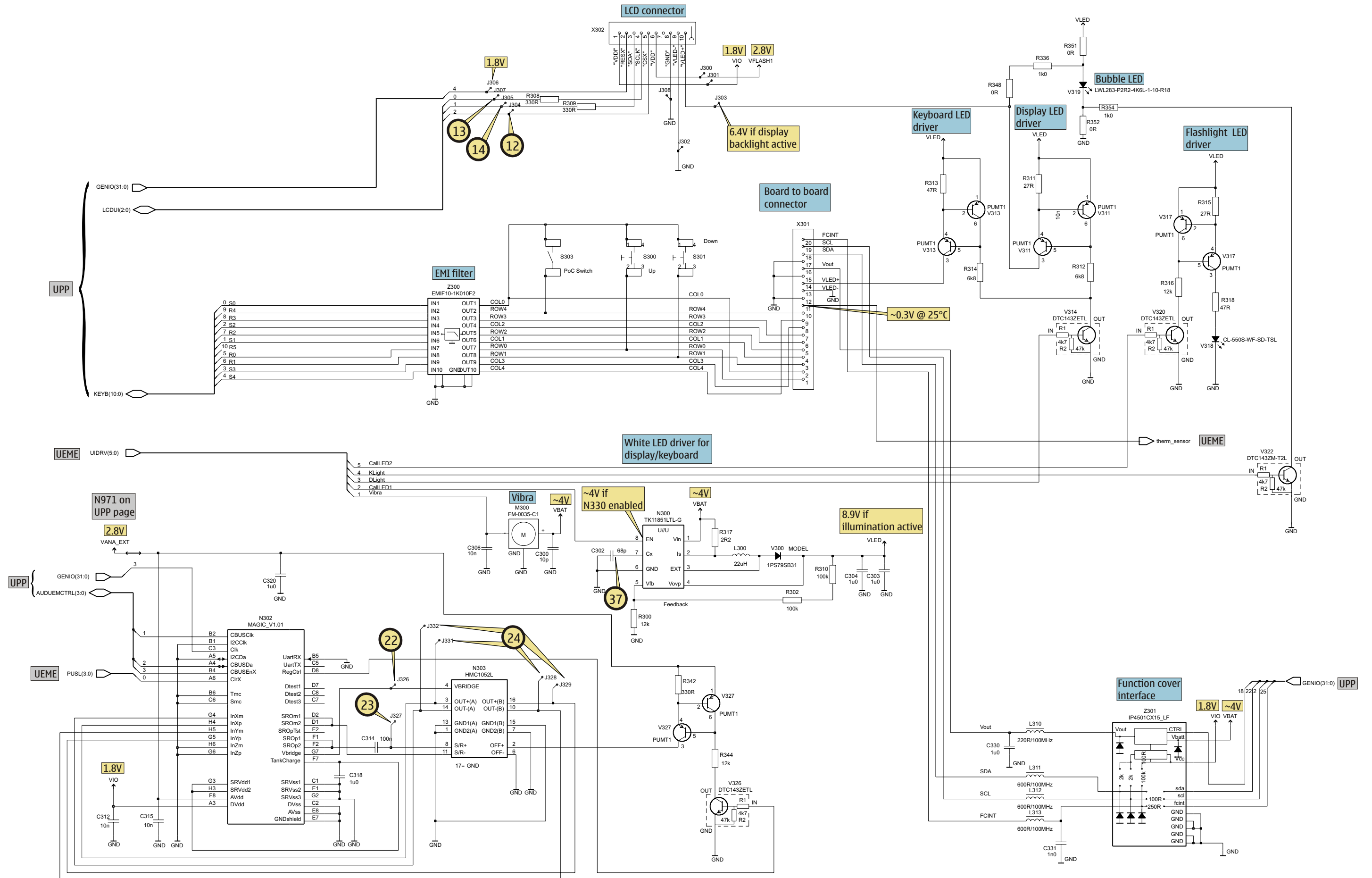

RF-part

Band	Channel	RX	VCO/RX	VC/RX	TX	VCO/TX	VC/TX
EGSM 900	37	942.4MHz	3769.6MHz	~2.71V	897.4MHz	3589.6MHz	~1.98V
GSM 1800	700	1842.8MHz	3685.6MHz	~2.38V	1747.8MHz	3495.6MHz	~1.59V
GSM 1900	661	1960MHz	3920MHz	~3.27V	1880MHz	3760MHz	~2.68V

	Vc1	Vc2	Vc3
EGSM RX	-	-	-
GSM1800 RX	-	-	-
GSM1900 RX	-	2.7Vpp	-
EGSM TX	-	-	2.7Vpp
GSM1800 TX	2.7Vpp	2.7Vpp	-
GSM1900 TX	2.7Vpp	2.7Vpp	-

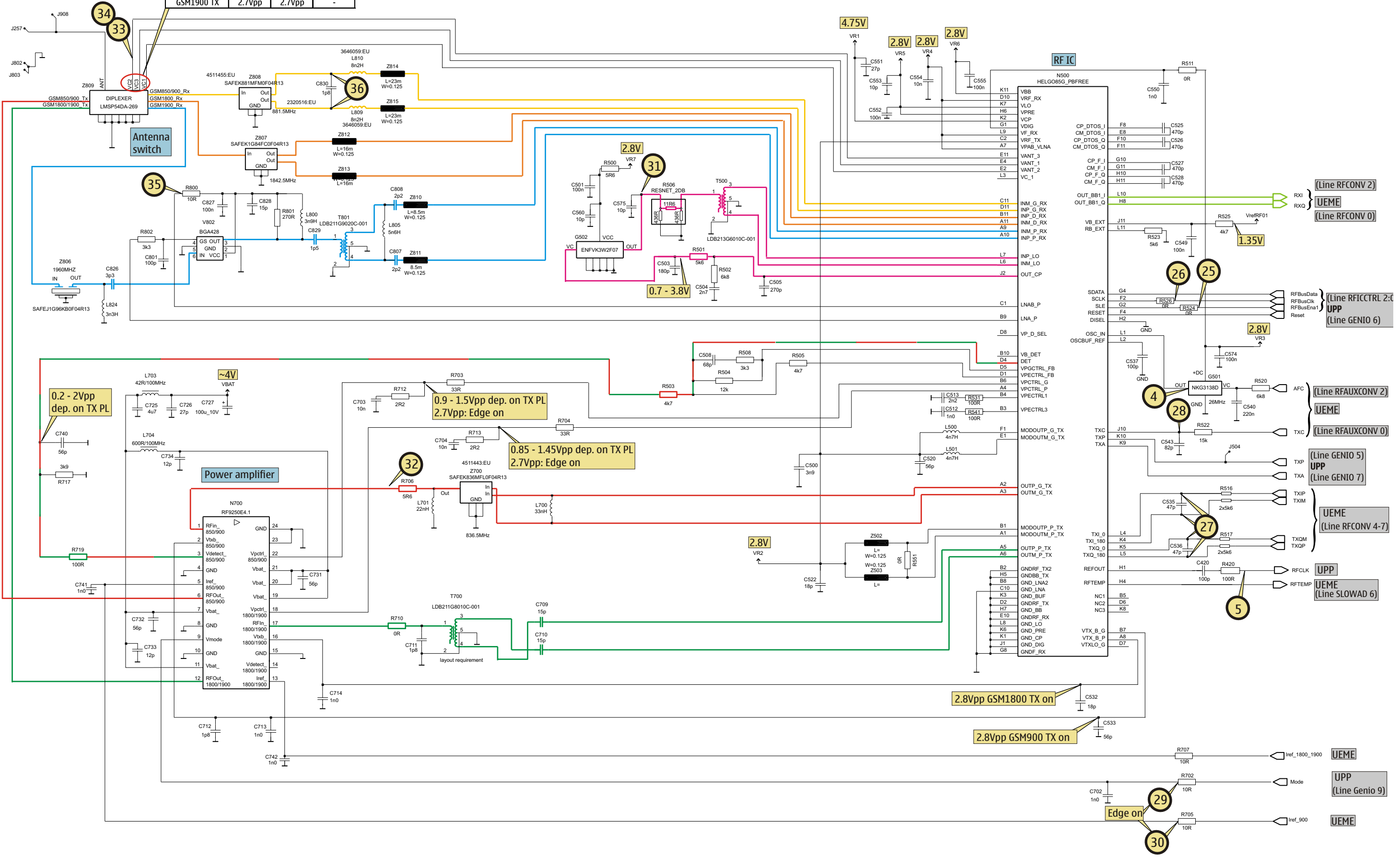

Signal overview

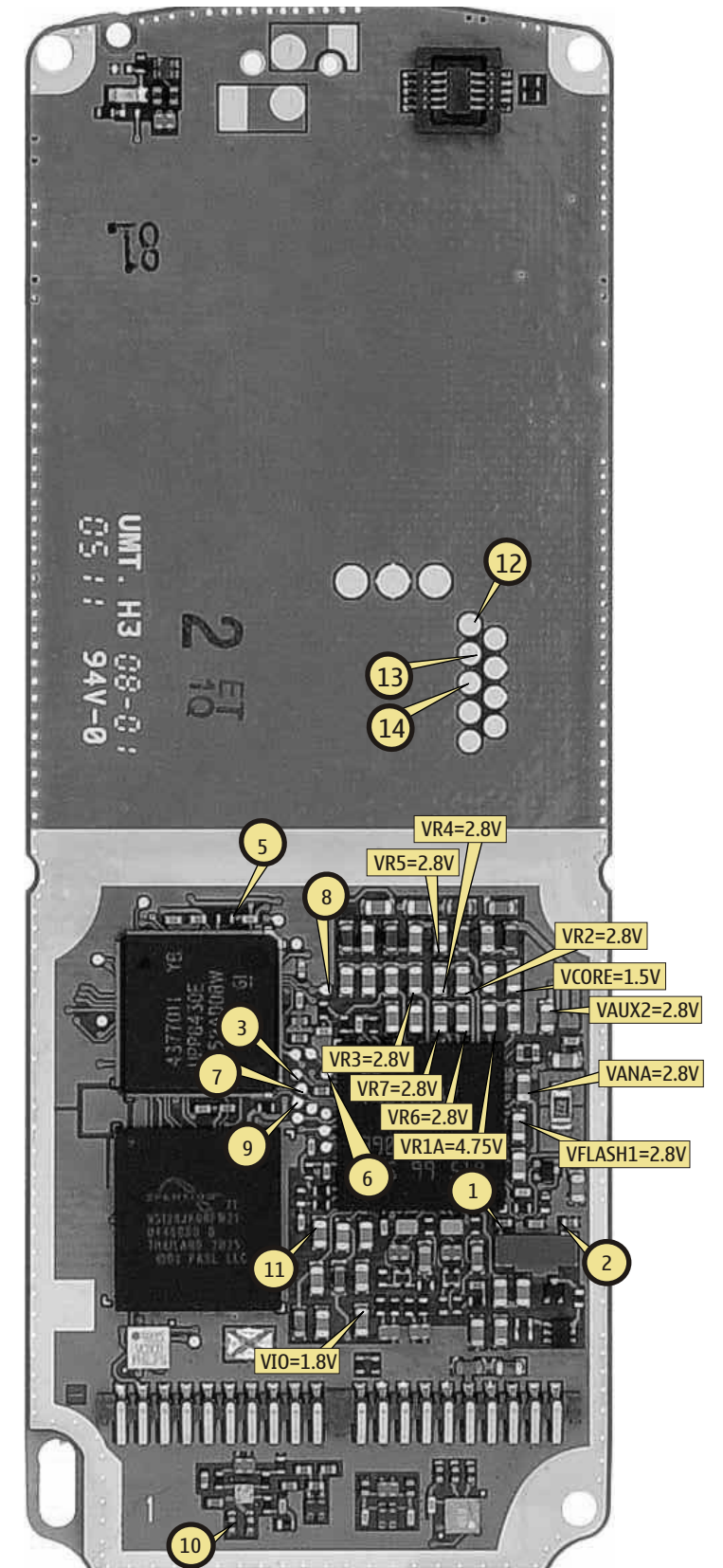
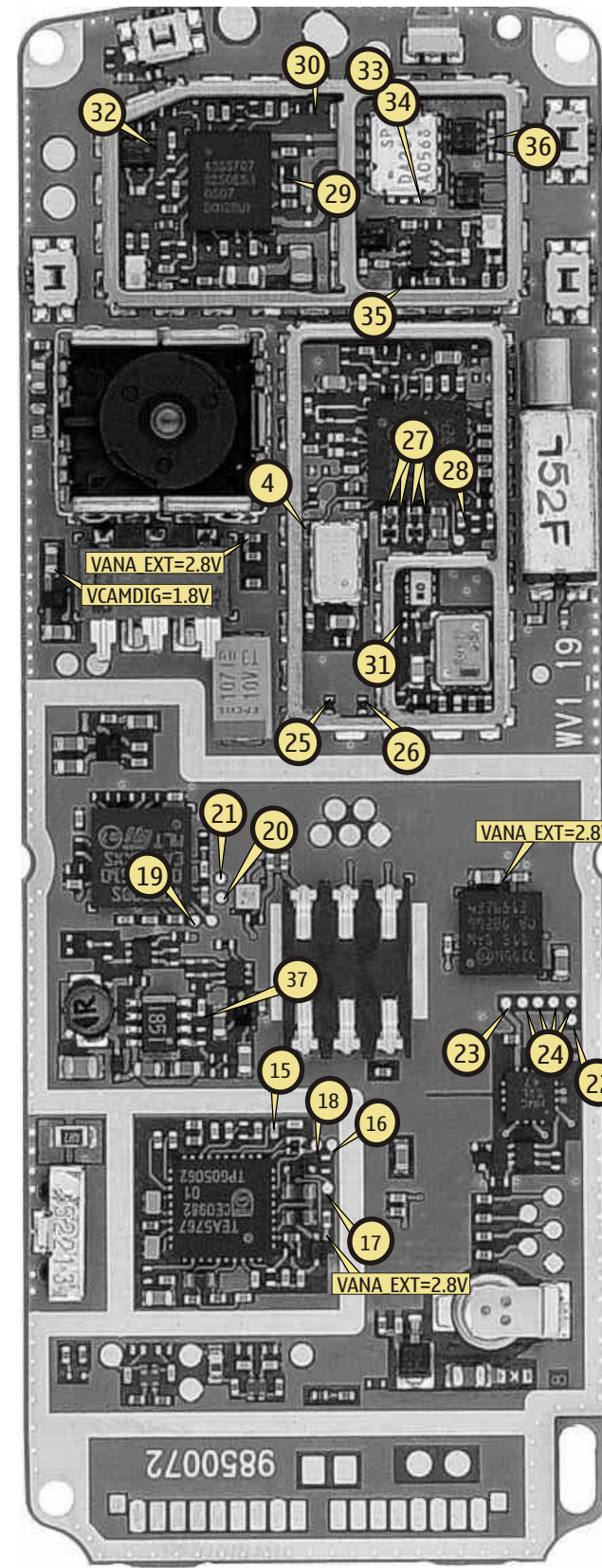
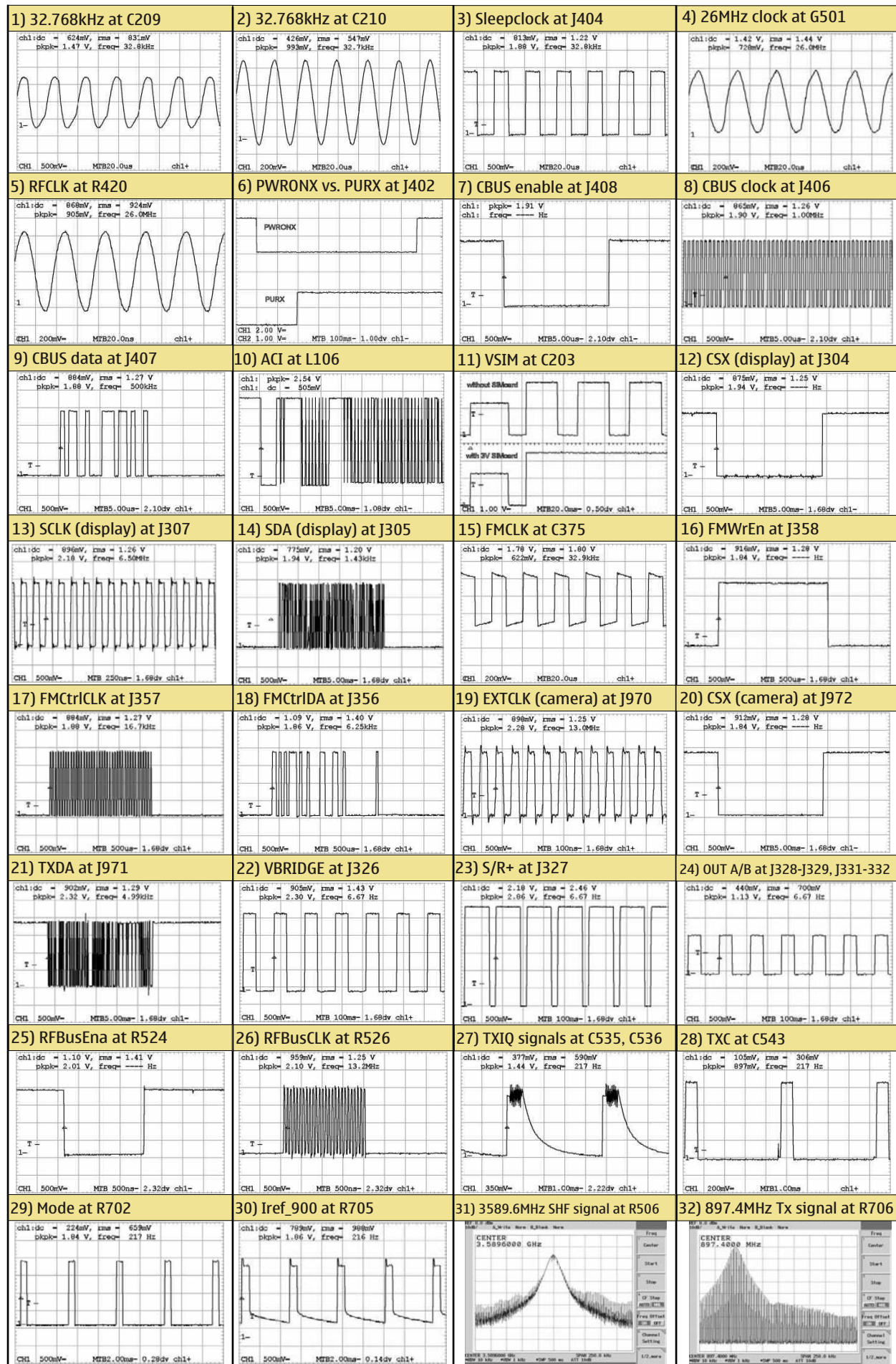

Component finder

B	C241	07	C390	K5	C740	B5	L357	05	R302	M5	R719	B5	
B200	07	C243	P6	C391	K5	C741	B5	L358	P6	R305	B6	R800	D3
C	C244	P4	C392	N3	C742	D5	L500	F4	R306	A7	R801	D3	
C100	H5	C245	05	C400	N3	C801	C3	L501	F4	R308	B7	R802	C3
C101	R4	C260	L5	C401	N3	C807	D2	L503	I3	R309	B7	R970	K7
C102	R3	C261	K6	C402	L3	C808	D2	L700	C6	R310	N5	R971	J7
C103	S4	C262	L6	C403	L4	C826	D3	L701	B6	R311	L6	R972	K6
C104	R3	C263	L5	C404	L4	C827	D3	L703	D5	R312	L5	R973	K7
C106	Q3	C264	L6	C405	L3	C828	D3	L704	C6	R313	P7	R974	J7
C107	Q5	C265	P4	C409	P2	C829	C2	L800	D2	R314	P7	R975	J6
C108	Q5	C283	05	C420	L3	C830	B2	L805	D2	R315	L6	S	
C109	Q6	C284	P5	C421	M4	C970	G5	L809	B2	R316	L7	S300	B1
C110	Q4	C285	05	C422	M5	C971	G5	L810	C2	R317	L6	S301	D1
C112	R3	C286	P6	C450	03	C972	K6	L824	D4	R318	L6	S302	A6
C113	Q7	C287	07	C451	03	C973	E8	M	R336	B2	S303	D7	
C114	Q5	C288	P7	C454	03	C974	E8	M300	G1	R342	01	T	
C115	S5	C289	N7	C470	02	C975	L7	N	R344	02	T500	H3	
C116	S5	C290	M7	C471	02	C976	L6	N150	J7	R348	L6	T700	D6
C117	Q6	C291	L7	C472	02	C977	J7	N300	M6	R350	N7	T801	C2
C118	Q6	C292	M5	C500	E4	C978	L6	N302	L2	R351	B2	V	
C119	Q5	C293	L5	C501	I2	C979	J6	N303	N2	R352	A2	V100	Q3
C120	Q4	C294	L5	C503	I3	C980	K6	N350	07	R354	A2	V300	M7
C127	R4	C295	L5	C504	I3	C981	K7	N356	05	R357	04	V311	L5
C128	R4	C296	M6	C505	I3	C982	H7	N500	F3	R359	P5	V313	P7
C129	R4	C297	L6	C508	E4	C983	G7	N700	C5	R360	P5	V314	P7
C150	P6	C298	M7	C512	E4	C984	F8	N970	H7	R361	N5	V317	L6
C151	05	C299	M6	C513	E3	C985	M5	N971	M5	R367	P6	V318	A3
C152	P6	C300	H1	C520	F4	C986	M5	R	R369	N5	V319	B2	
C153	05	C302	M6	C522	E4	C987	M5	R100	R3	R388	K5	V320	L7
C154	06	C303	M6	C525	F2	D	R101	R4	R389	L5	V322	07	
C155	B2	C304	M6	C526	F2	D200	N6	R102	S4	R420	L3	V326	02
C156	P6	C306	H2	C527	F2	D400	M3	R103	R3	R421	M4	V327	02
C157	P5	C310	B7	C528	F2	D450	03	R104	R4	R422	M5	V356	04
C158	P6	C312	L3	C532	E3	D970	K6	R105	Q5	R423	M5	V357	P5
C159	R5	C314	M2	C533	E3	F	R106	Q5	R450	N4	V802	D3	
C161	P6	C315	K2	C535	G3	F100	Q2	R107	Q6	R501	I3	X	
C173	J6	C318	L1	C536	G3	G	R108	Q6	R502	I3	X100	H6	
C174	J6	C320	K2	C537	G4	G300	P2	R109	S4	R503	E3	X301	Q5
C188	I7	C330	Q6	C540	H4	G501	G4	R110	Q4	R504	E4	X302	B6
C189	I6	C331	S6	C543	G3	G502	H3	R150	P5	R505	E3	X387	L4
C200	M7	C350	M7	C549	F2	L	R151	B2	R506	H3	X970	F6	
C201	M7	C352	Q7	C550	F4	L100	Q2	R152	B3	R508	E4	Z	
C202	M7	C353	Q7	C551	F4	L101	S4	R153	P6	R511	G4	Z300	Q2
C203	04	C357	P5	C552	G3	L102	S5	R154	P6	R516	G3	Z301	S6
C204	K6	C358	05	C553	G3	L103	Q5	R155	P6	R517	G3	Z700	B6
C205	L5	C359	04	C554	E3	L104	Q6	R156	P6	R520	H4	Z806	C4
C206	N7	C361	N6	C555	G2	L105	Q6	R157	P5	R522	G2	Z807	C2
C207	P5	C362	P5	C560	I2	L106	S3	R158	R5	R523	G2	Z808	B2
C209	07	C363	P6	C574	H4	L107	S3	R159	R5	R524	I4	Z809	B3
C210	07	C364	N5	C702	C5	L150	A2	R160	P6	R525	G2		
C212	N7	C365	06	C703	B6	L186	J7	R164	P5	R526	I4		
C215	P6	C366	06	C704	D6	L187	J7	R165	P5	R531	E3		
C218	N4	C367	P5	C709	D6	L206	P5	R166	P6	R541	E3		
C220	N4	C370	P5	C710	D6	L260	L5	R167	P5	R551	F4		
C221	07	C371	P6	C711	D6	L261	K6	R171	06	R700	07		
C223	L6	C372	P6	C712	B6	L262	L7	R172	06	R702	C5		
C225	M6	C373	N5	C713	B5	L263	L5	R200	N7	R703	C6		
C226	L6	C374	N5	C714	D5	L264	L6	R202	04	R704	D6		
C231	K5	C375	N5	C725	D4	L265	P4	R203	04	R705	B4		
C234	M5	C378	P6	C726	D6	L300	M7	R204	07	R706	B6		
C236	M4	C379	P5	C727	I5	L310	Q7	R206	04	R707	D5		
C237	M4	C380	N6	C731	C6	L311	R6	R207	04	R710	D6		
C238	M7	C382	N6	C732	B5	L312	R6	R208	05	R712	C6		
C239	04	C384	N6	C733	C5	L313	R6	R209	05	R713	D6		
C240	04	C385	N6	C734	C6	L356	05	R300	M6	R717	B5		

